



TECHNOLOGIES

Shredders technology



The shredder for waste handling systems

www.jnd.co.uk

Reduction Technology

vertical shaft principle

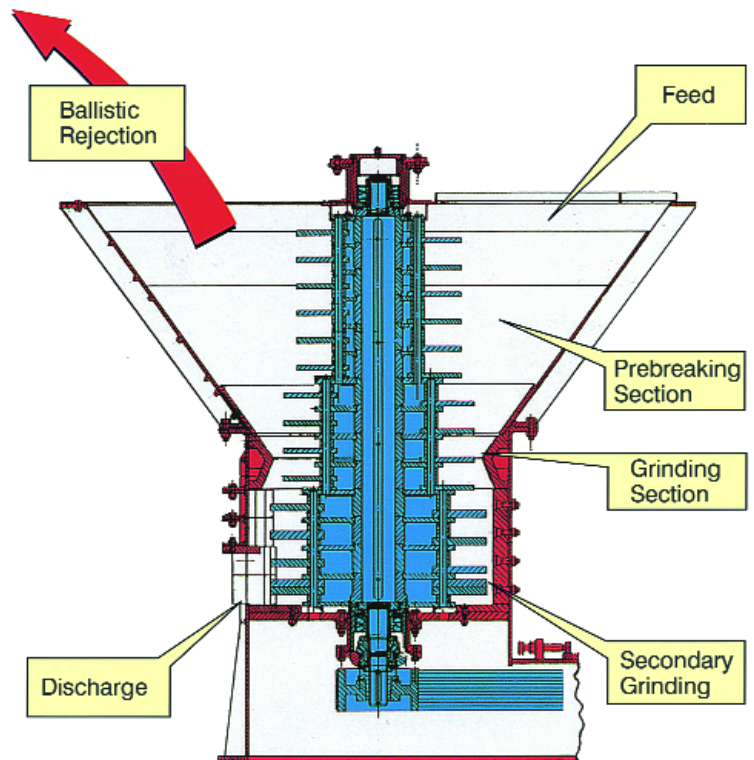

Jenkins of Retford (founded 1896) and Newell Dunford (founded 1892) are internationally recognised names in the field of process engineering. Operating today as JND Technologies Ltd. (incorporating Magco-Tollemache), thermal and size reduction solutions are provided to a diverse range of industry such as food processing, chemical, minerals, metals, gypsum, glass and recycling.

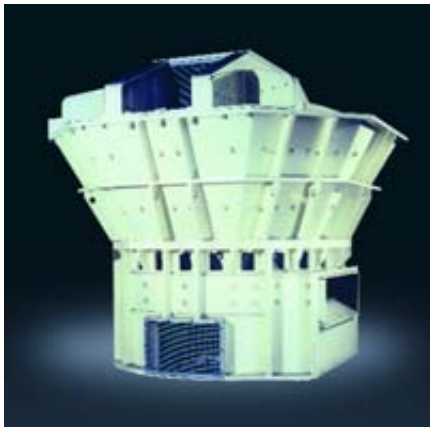

Model 72 Shredder - one of nine units despatched to Iran.

Magco Tollemache entered the solid waste processing field in the early sixties with the introduction of the Vertical Shaft Shredder designed specifically for shredding household, civic amenity and industrial waste. The success of the Shredder has resulted in an extended size range, with capacities of up to 100 tonnes/hour. All models throughout the range have large feed openings which allow the waste to be fed direct without the need for presorting. Once inside the cone, the shredder ballistically rejects items that cause damage and then proceeds

to pre-break the material until the waste reaches the grinding section where the final size reduction takes place. The Ballistic Rejection automatically ejects heavy or resilient objects which may damage the machine. This is accomplished through a reject hood on top of the shredder opposite the feed opening. No additional power or ancillary equipment is necessary for this important feature.

MODEL	25 Fines Grinder	32	42	58	72	92
Application	Matured Compost	Municipal domestic and light industrial waste	Municipal domestic and light industrial waste	Municipal domestic and light industrial waste	Municipal bulky and domestic waste	Municipal bulky and domestic waste
Capacity	10 T.P.H.	12/15 T.P.H.	18/30 T.P.H.	30/40 T.P.H.	40/60 T.P.H.	60/100 T.P.H.
Motor	55kW	100kW	186kW	260kW	373kW	560kW
Throat Dimensions (mm)	650	800	1067	1500	1829	2337
Feed Opening (mm)	450 x 650	750 x 990	914 x 1524	1140 x 1750	1220 x 2124	1220 x 2438
Approx Weight. (kg)	1770	5000	9944	34500	46000	75000

specification



TECHNOLOGIES

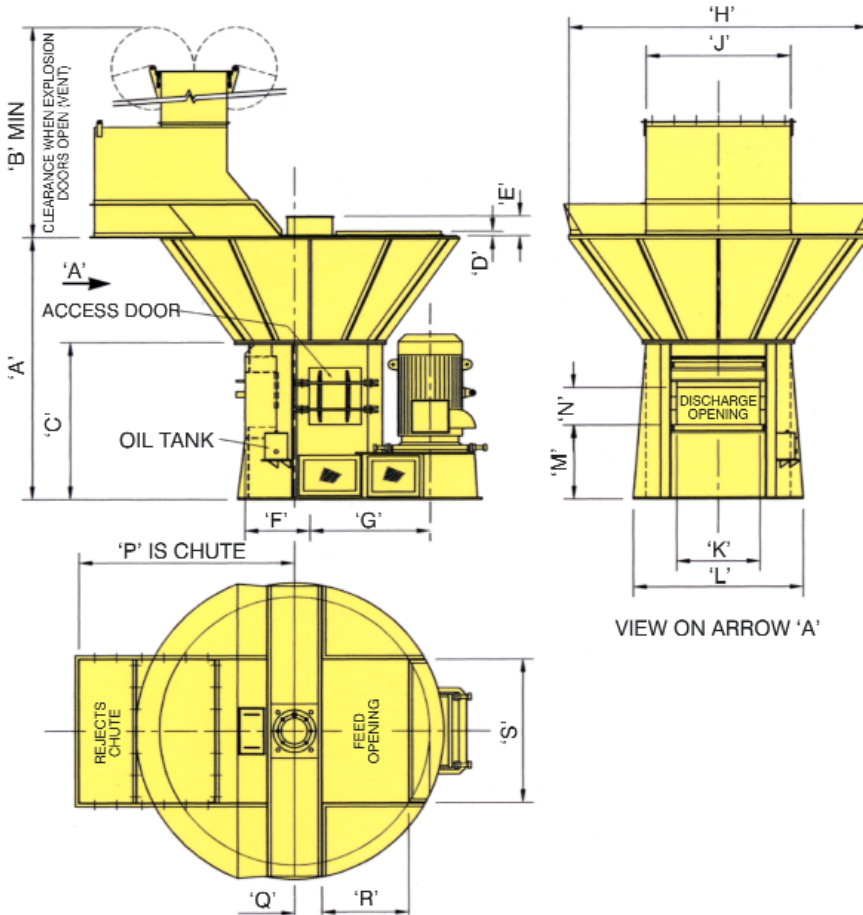
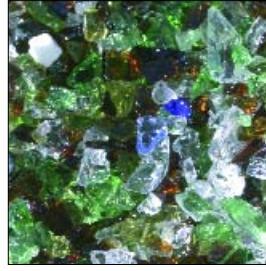

Processes

LANDFILL COMPACTION

Crude waste treated by shredding produces a homogenous material that has immediate aesthetic and environmental benefits such as the reduction of flies, vermin, fires, and extended tip life due to the increased compaction obtained. Shredding also eradicates the need for top cover.

TRANSFER STATIONS

Where space is available for landfill but the site is remote from the collection area, the solution could be the installation of a transfer station. With ever increasing fuel costs it is essential that economic payloads are made between the station and the landfill site. The inclusion of shredding at the station increases the efficiency of the compaction containers or balers.

MODEL	A	B	C	D	E	F	G	H	J	K	L	M	N	P	Q	R	S
25	1342	-	857	-	210	458	869	1320	-	448	652	150	228	-	127	450	650
32	2700	-	1550	50	210	610	1800	2728	-	800	1641	760	400 265	-	270	750	990
42	2781	3600	1665	50	210	686	1267	3150	1524	877	1791	784	400 265	2238	289	914	1524
58	2635	3200	1302	170	720	-	-	3550	1750	1134	1890	748	354	2865	435	1140	1750
72	6990	3890	1490	230	850	-	-	4030	2124	1548	2970	576	519	3450	610	1220	2124
92	3210	3890	1940	-	1000	-	-	4592	2438	1840	3734	654	731	2200	610	1220	2438

Domestic, commercial and most types of solid industrial waste have been treated by the Magco Tollemache Shredder with high degrees of availability



Processes

RECYCLING

The need to recycle industrial process scrap is becoming more necessary due to both environmental and economical reasons. The Magco Tollemache Shredder with its large feed opening and open discharge is ideal for reducing bulky, and usually unmanageable waste to a size suitable for further processing.

COMPOSTING

High organic content waste is suitable for composting and whether this is carried out by using a simple windrow or by a mechanised form of fermentation, some method of raw material preparation is required. The Magco Tollemache Shredder is ideal for this purpose. Should a very fine compost be required, the Fines Grinder can be used after fermentation.

FINE GRINDING

Encouraged by the Government, many organisations are developing schemes to produce composts from unusual sources of wastes. Common to most of these ideas is the necessity to fine grind the materials in order to obtain a good, consistent, mixed product. The Magco Tollemache Fines Grinder has successfully been incorporated into such installations.

PREPARATION FOR INCINERATION

Whether mass burning, or as part of a more sophisticated incineration method, preparation of raw waste will increase the efficiency of the burning process. The Magco Tollemache Shredder is ideal as a primary shredder, particularly as part of a full Fuel Preparation Plant.

WASTE TO ENERGY

Household and most industrial solid wastes contain high energy, and given the increasing constraints and landfill taxation, more consideration is being directed towards extracting this energy, both as a means of raising power and disposing of the waste. Raw material preparation in the form of shredding and screening is required for these waste to energy plants.

TEST FACILITIES

All the above processes are typical of those undertaken by the Magco Tollemache Shredder. In-house facilities are available to test other waste materials.



CALCINING
CONVEYING
COOLING
CRUSHING
DRYING
FEEDING
GASIFICATION
GRINDING
SCREENING
RECYCLING



TECHNOLOGIES

A Langley Holdings Company

JND Technologies Ltd

Thrumpton Lane, Retford
Nottinghamshire, DN22 7AN, England
Tel +44 (0)1 777 706 777
Fax +44 (0)1 777 713 192

www.jnd.co.uk

The information contained within this brochure is deemed to be correct at the time of going to press. Due to the policy of continued improvement, we reserve the right to change any specification without prior notice. ERRORS & OMISSIONS EXCEPTED